

Series 4600F

ARMSTRONG

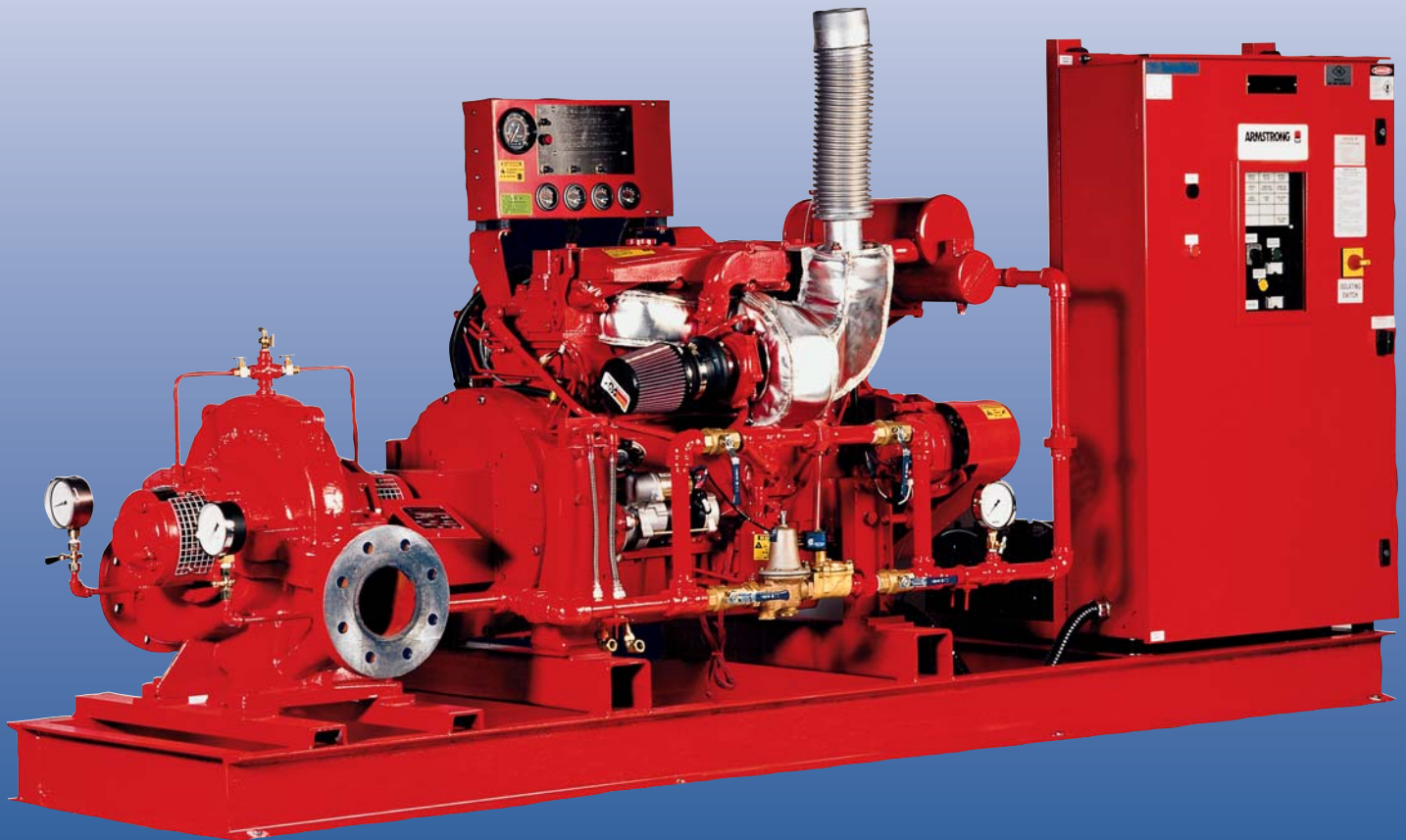

HSC Fire Pumps & Packaged Systems

FILE NO:	F43.11
DATE:	May 26, 2008
SUPERSEDES:	F43.11
DATE:	Dec. 15, 2007

Series 4600F - Truly Superior

The Series 4600F, drawing on over 100 years of pump design expertise and leadership, is the state of the art in Horizontal Split Case pumps. It meets or exceeds the requirements of NFPA and testing laboratories involved in fire protection such as UL, ULC, & FM.

The family of pumps capitalize on the "Tilted Parting" concept to minimize turbulence at the eye of the impeller by its straight laminar approach, thus maximizing efficiency. The family was designed with commonality of parts, low installation cost, and ease of maintenance objectives.

The pumps' compact sizes are ideally suited for space saving packages and retrofit applications.

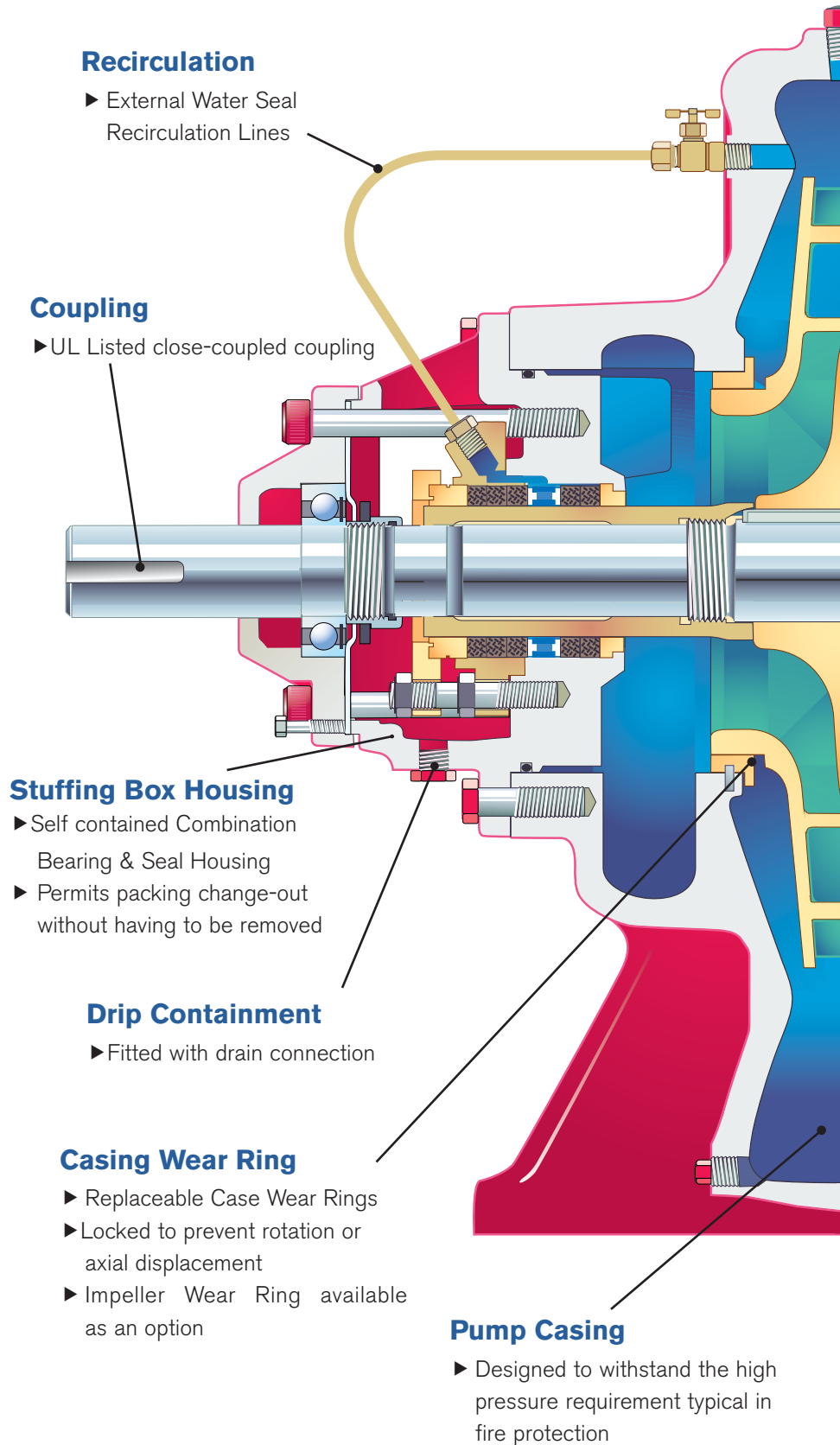

Recirculation

- ▶ External Water Seal Recirculation Lines

Coupling

- ▶ UL Listed close-coupled coupling

Stuffing Box Housing

- ▶ Self contained Combination Bearing & Seal Housing
- ▶ Permits packing change-out without having to be removed

Drip Containment

- ▶ Fitted with drain connection

Casing Wear Ring

- ▶ Replaceable Case Wear Rings
- ▶ Locked to prevent rotation or axial displacement
- ▶ Impeller Wear Ring available as an option

Pump Casing

- ▶ Designed to withstand the high pressure requirement typical in fire protection

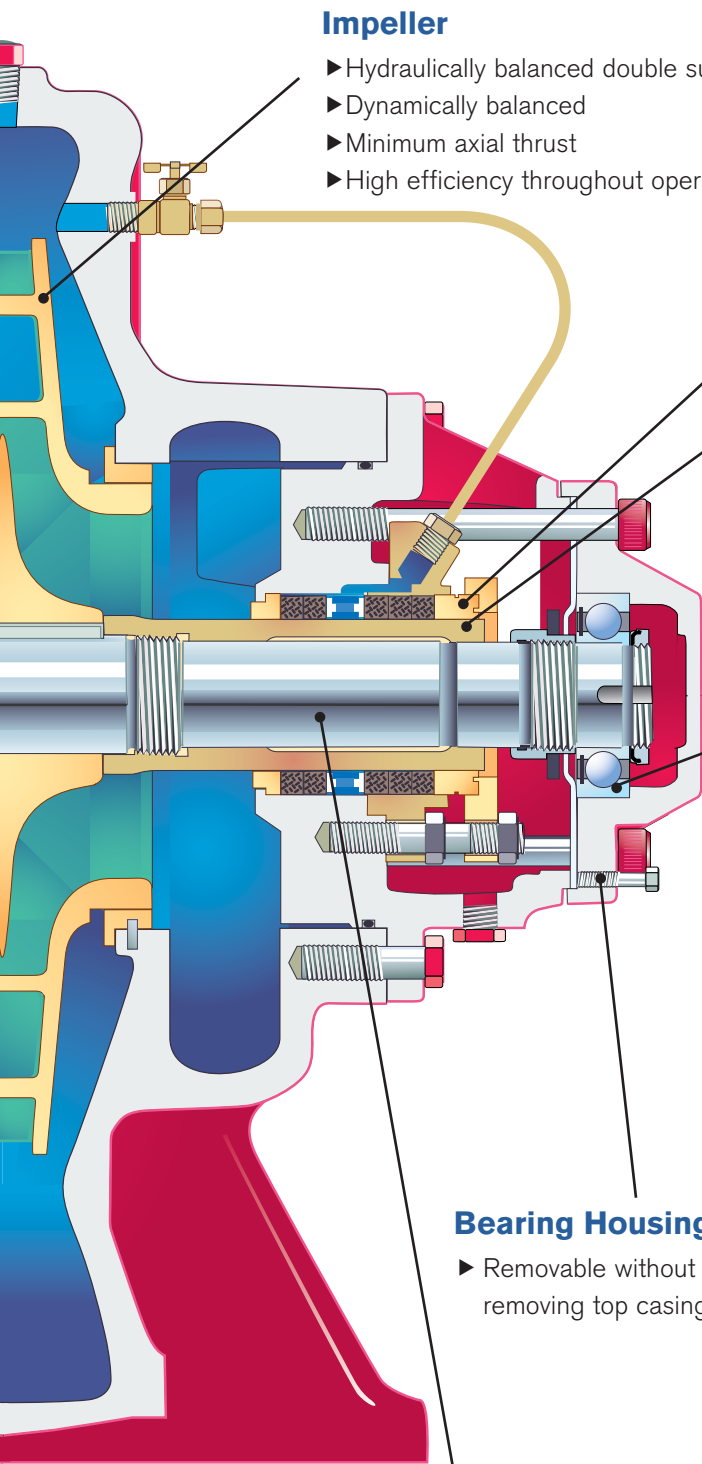

Impeller

- ▶ Hydraulically balanced double suction
- ▶ Dynamically balanced
- ▶ Minimum axial thrust
- ▶ High efficiency throughout operating range

Shaft Sealing with Packing

- ▶ Three-piece Split Gland standard
- ▶ Packing replaceable without disturbing wetted parts
- ▶ Stuffing Box Extension designed for easy access

Shaft Sleeves

- ▶ Replaceable bronze sleeves
- ▶ Protects shaft throughout Stuffing Box

Bearings

- ▶ Easy removal with bearing nut
- ▶ Sealed, permanently greased bearings
- ▶ Low Friction Lost Bearing
- ▶ Maintenance free

Tilted Parting Design Casing

- ▶ Permits laminar approach to eye of Impeller
- ▶ Lower NPSH required
- ▶ Lower pump profile
- ▶ Minimum pump footprint
- ▶ Removeable rotating element without disturbing piping
- ▶ Low foot-mounted Casing to reduce vibrations

Bearing Housing

- ▶ Removable without removing top casing

Shaft

- ▶ Minimum deflection for long bearing life
- ▶ Minimum vibrations
- ▶ Identical shaft and parts for left and right-hand drives

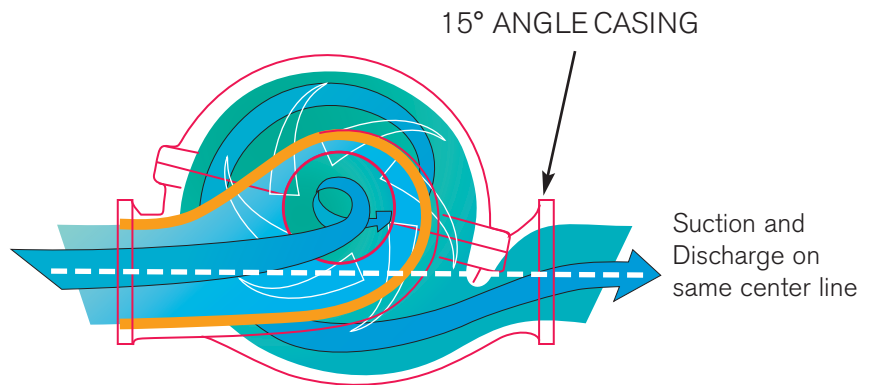

HSC Fire Pumps & Packaged Systems

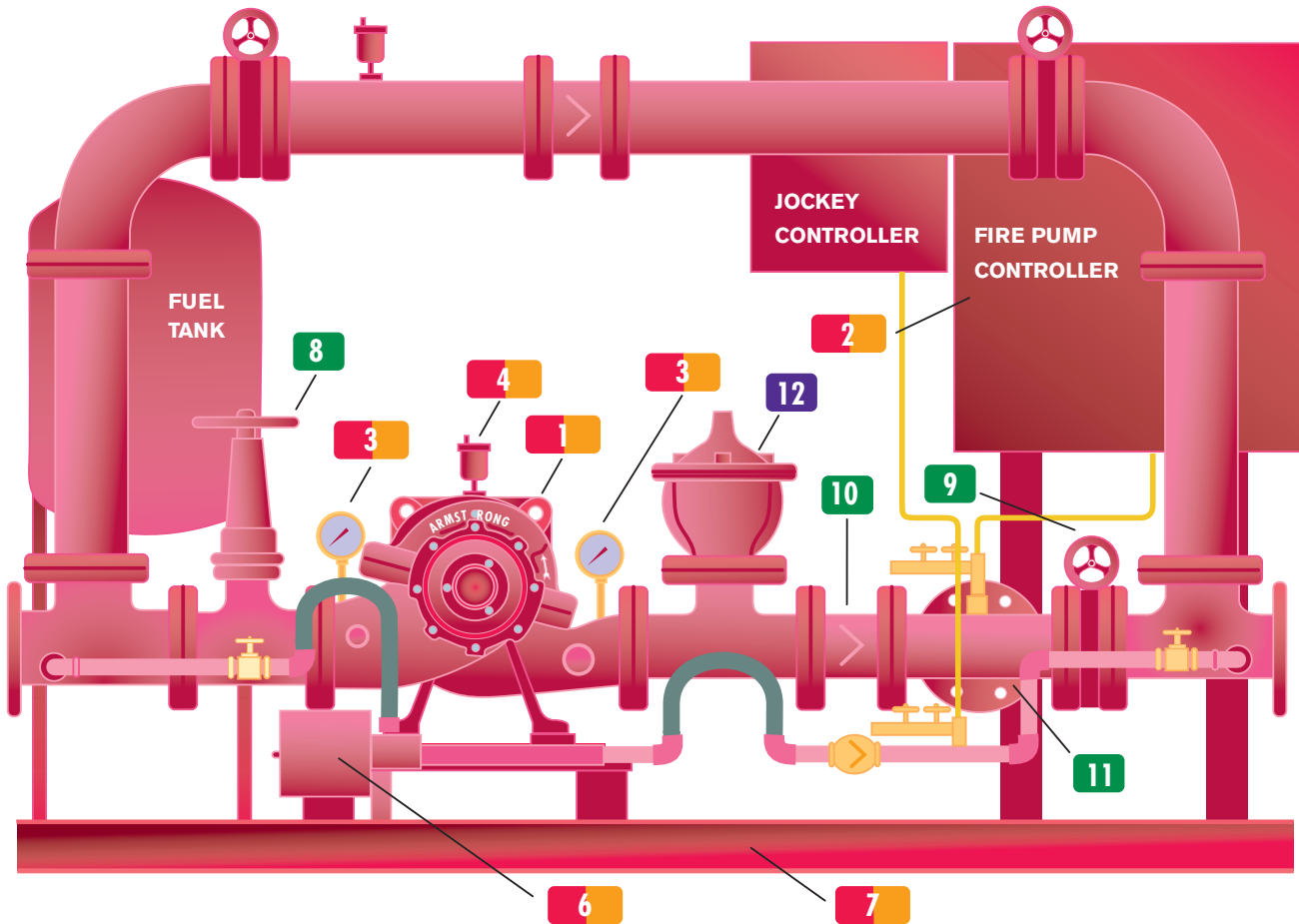

Horizontal Fire Systems

With years of experience in fire protection industry, Armstrong can supply fire pump systems with all necessary accessories ready for site installation.

GUARANTEED ADVANTAGES

- ▶ Simplifies piping design
- ▶ Single source unit responsibility
- ▶ A complete package that will meet NFPA-20 requirements

FIRE PUMP - ELECTRIC DRIVEN

1. Pump/motor
2. Fire pump controller (with optional transfer switch)
3. Suction and discharge gauges
4. Air release valve
5. Casing relief valve (not shown)
6. Jockey pump
7. Common base

FIRE PUMP - DIESEL ENGINE DRIVEN

1. Pump/engine assembled with
 - ▶ Cooling system
 - ▶ Fuel system
 - ▶ Battery system
 - ▶ Exhaust system
2. Fire pump controller
3. Suction and discharge gauges
4. Air release valve
6. Jockey pump
7. Common base

ACCESSORIES - ADDITIONAL (ELECTRIC OR DIESEL)

8. Suction OS&Y gate valve
9. Discharge butterfly valve
10. Check valve
11. Test tee

ACCESSORIES - SPECIAL FOR DIESEL OR VFD

12. Main relief valve
13. Enclosed cone (not shown)

- Features common to electric and diesel
- Accessories - (electric or diesel)
- Accessories - special for diesel or VFD

► Fire Pump Coverage Chart

Electrical 60 Hz

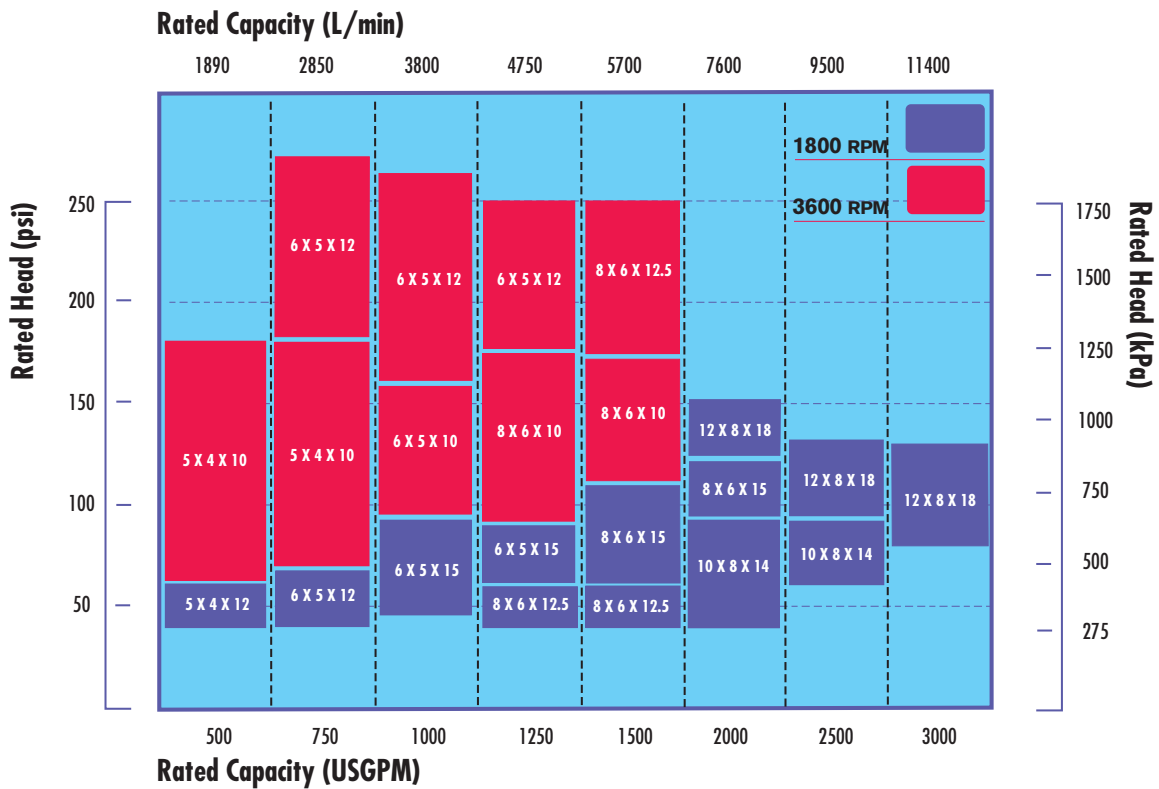

Electrical 50 Hz

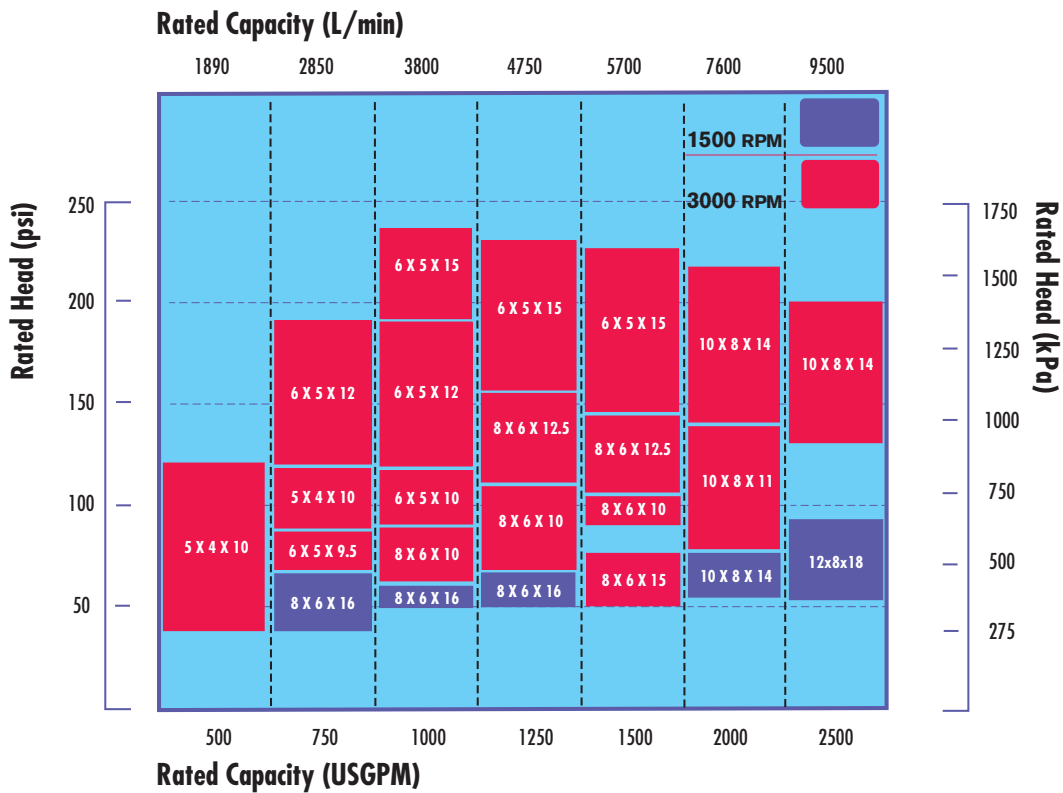

Note: Higher ranges may be available for diesel driven applications.

► Typical Specifications

Horizontal Fire Pump - Electric Motor Driven*

Supply and install as indicated on plans one (1) fire pump system consisting of:

1. FIRE PUMP

One Armstrong, SERIES 4600F, Size _____ double suction horizontal split case fire pump listed by [Underwriters Laboratories of Canada (ULC)], [Underwriters Laboratories Inc. (UL)] and/or [approved by Factory Mutual (FM)] having a capacity of _____ USGPM for a pressure boost of _____ PSIG. Suction pressure _____ PSIG.

Pump casing shall be of cast iron, axially split with a 15° angle that will minimize NPSH requirements and dimensions. Lower half shall contain suction and discharge nozzles. Suction and discharge connections shall be on the same elevation. Top half and rotating element shall be removable without disturbing the piping. Casing shall be fitted with replaceable bronze wearing rings. Impeller shall be bronze, double suction, enclosed type fully balanced and keyed to an alloy steel shaft. Shaft shall to be fitted with replaceable bronze sleeves. Shaft shall be mounted in two dust tight deep grooves, sealed, and permanently greased ball bearings.

Bearings shall be mounted in cartridge type housing so that they shall be replaceable without opening pump casing. Bearings shall be easily removable by rotating bearing removal nut. No special tools or bearing puller are to be necessary.

Each stuffing box shall be fitted with a three piece bronze gland. Stuffing box shall be fitted with a stuffing box extension to facilitate the packing rings removal. Packing rings shall be removable without disturbing wetted parts or the pump bearings. Water seal recirculation lines made from non-corroding material shall be piped to pump volute.

2. ELECTRIC MOTOR

The fire pump shall be directly coupled through flexible coupling to a horizontal electric motor with a maximum HP of _____ at _____ RPM, _____ VOLT, _____ PHASE _____ CYCLE. Motor shall be UL Listed for fire pump service, open drip proof, standard efficiency with 1.15 service factor.

3. MINIMUM FITTINGS

The pump shall be supplied with the following accessories:

- One (1) combination suction gauge 3½" dial type with ¼" cock and lever handle.
- One (1) discharge gauge, 3½" dial type, with ¼" cock and lever handle.
- One (1) air release valve.
- One (1) casing pressure relief valve.

4. OTHER ACCESSORIES

Pump shall be fitted with one (1) eccentric suction reducer and one (1) concentric discharge increaser, as required (by mechanical contractor) to fit NFPA20 recommended piping sizes.

One (1) outside test header shall be supplied with one (1) set of ____ x 2½" hose valves with caps and chains.

EXPERIENCE BUILDING...

5. FIRE PUMP CONTROLLER

The fire pump controller shall be specifically approved for fire pump service by [ULC], [UL] and/or [FM]. The controller shall be of the combined manual and automatic stop, _____ starting method, Model _____ as manufactured by _____. All equipment shall be enclosed in an approved drip proof enclosure. The control equipment shall be completely assembled, wired and tested at point of manufacture prior to shipment.

Circuit breaker shall have an interrupting capacity of _____ kAmps or a withstand rating of _____ kAmps RMS.

Water pressure switch shall be suitable for _____ PSI working pressure.

5A. FIRE PUMP CONTROLLER AND AUTOMATIC TRANSFER SWITCH COMBINATION

The automatic transfer switch controller combination shall be approved by [UL], [ULC] and/or [FM], Model _____ as manufactured by _____. The automatic transfer switch and the pump controller shall each be mounted in separate enclosures, mechanically attached to form one unit and provide for protected interlock wiring.

The automatic transfer switch shall be capable of automatic power transfer from normal to alternate _____ [generator] / [second utility] emergency power source in case of normal supply failure and automatically re-transfer after restoration of normal power conditions.

6. JOCKEY PUMP

The jockey pump shall be manufactured by _____ Model _____ for a capacity of _____ USGPM and a pressure boost of _____ PSIG. The jockey pump shall be driven by an [open drip proof] [totally enclosed fan cooled] electric motor of _____ HP _____ RPM _____ VOLT _____ PHASE _____ CYCLE.

7. JOCKEY PUMP CONTROLLER

The jockey pump shall be controlled by an automatic jockey pump controller model _____ as manufactured by _____ with full voltage starter.

8. MOUNTING AND TESTING

The fire pump shall be suitable for a maximum working pressure of _____. The fire pump shall be hydrostatically tested at twice the maximum working pressure for at least 5 minutes. The fire pump shall be performance tested at rated speed. The fire pump shall furnish not less than 150% of rated capacity at a pressure not less than 65% of rated head. The shut-off total head of the fire pump should not exceed 140% of total rated head. A certified test curve, indicating the flow, head, power and efficiency shall be supplied for the field acceptance test. The fire pump and electric motor shall be base mounted and aligned at the pump manufacturer's factory. Final alignment shall be made after installation on site

* Please refer to Armstrong Fire Pump Catalogue for Diesel Driven Typical Specifications.

S. A. Armstrong Limited
23 Bertrand Avenue
Toronto, Ontario
Canada, M1L 2P3
T: (416) 755-2291
F (Main): (416) 759-9101

Armstrong Pumps Inc.
93 East Avenue
North Tonawanda, New York
U.S.A., 14120-6594
T: (716) 693-8813
F: (716) 693-8970

Armstrong Holden Brooke Pullen
Wenlock Way
Manchester
United Kingdom, M12 5JL
T: +44 (0) 161 223 2223
F: +44 (0) 161 220 9660

ARMSTRONG 



© S.A. Armstrong Limited 2008

For Armstrong locations worldwide, please visit www.armstrongpumps.com